

815

Non-return valve with dual-plate
05 System

Technical Data Sheet

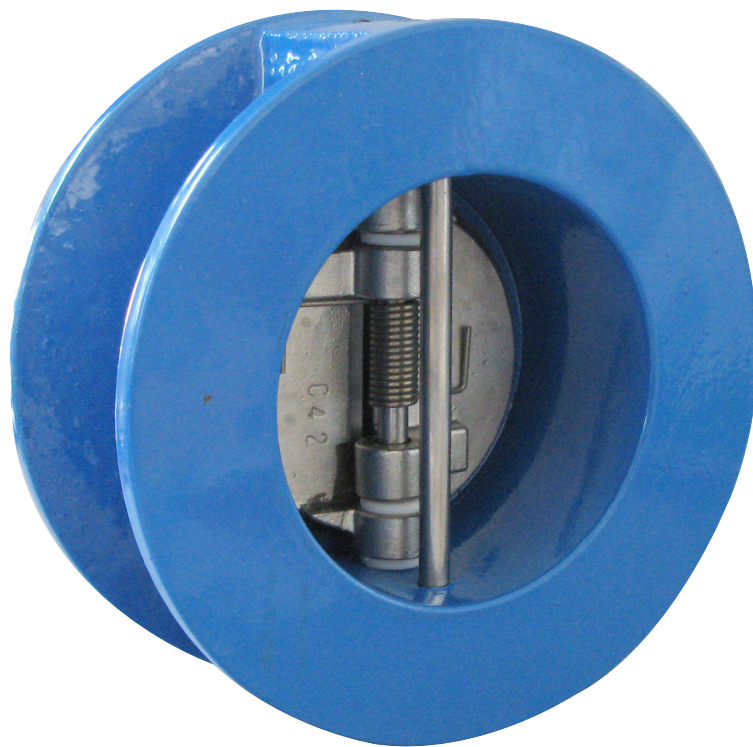

Description

The 815 non-return valve's tightness is ensured by the spring force distribution on the plates guaranteeing a good press on the seat's seal.

- Operating position : horizontal and vertical ascending and descending
- Compact
- Very low head loss
- Sealing : metal on elastomere seat



815

Non-return valve with dual-plate - 05 System

DN	PN	PFA in bar	PS in bar				Cat.	Ref.	Weight Kg
			L1	L2	G1	G2			
2 50	25	25	25	25	20	25	I	149B3290	2,5
2 1/2 65	25	25	25	25	15	25	I	149B3291	3,2
3 80	25	25	25	25	12	25	I	149B3292	3,4
4 100	25	25	20	25	10	25	I	149B3293	5,6
5 125	25	25	16	25	0,5	25	I	149B3294	8,1
6 150	25	25	13	25	0,5	23	I	149B3295	10,4
8 200	25	25	10	25	0,5	17	I	149B3296	18,5
10 250	25	25	10	25	0,5	14	I	149B3297	29,5
12 300	25	25	10	25	0,5	11	I	149B3298	44,1
14 350	25	25	10	25	x	10	I	149B2650	78
16 400	25	25	10	25	x	8	I	149B3340	101
18 450	25	25	10	25	x	7	I	149B2652	146,9
20 500	25	25	10	25	x	7	I	149B2653	189,7
24 600	25	25	10	25	x	5	I	149B2654	290

Important notice :

The indicated pressure for the different categories of fluids (L1/L2/G1/G2) is under no condition a guarantee of use. Therefore, it is essential to validate the use of products under given operating conditions. The operating instructions are available on our website www.socla.com or by requesting from our sales department.

Technical features

Operating temperature	-10 °C at 100 °C (Seal EPDM) / 80 °C (Seal NBR)
Permissible operating pressure (PFA) in water	See table above
Maximum permissible pressure (PS) other mediums	See table above
Connection	Mounting between flanges, PN (see table)
Mediums	Clear water, gas

Nomenclature and materials

N°	Description	Materials	EURO	ANSI	
1	Body*	Cast iron / Epoxy	EN-GJS-400.15	ASTM A 536 65-45-12	
2	Closing system	DN 50 - 300 & 400	Stainless steel	GX5CrNi19-10	AISI 304
		DN 350 & 450 - 600	Aluminium bronze	CuAl10Fe5Ni5	C95400
3	Seal	DN 50 - 300 & 400	EPDM		
		DN 350 & 450 - 600	NBR (nitrile)		
4	Spring	Stainless steel	X5CrNiMo17-12-2	AISI 316	
5	Stem	Stainless steel	X3CrNiMo17-13-3	AISI 316	
6	Bearings	PTFE			
7	Eye bolt	DN > 150	Steel XC15		
8	Plug	Brass			

* DN 350 & 450 at 600 : Outside Epoxy cover only

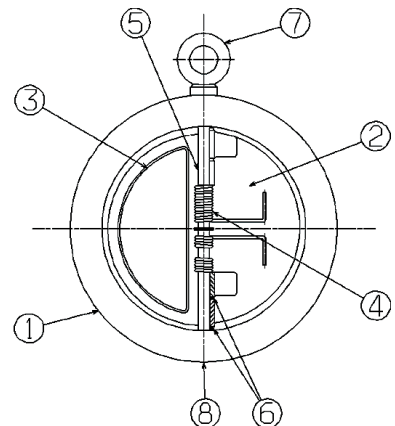

Approvals



International construction Standards :

CE Conformity Directive 2014/68/UE
Flange drilling according to EN 1092-2
Size according to EN558-1 series 500

Application

Pumping, supply, general industry.

Use of these valves on circuits equipped with piston pump or piston compressor is not recommended.

Installation

Installation :

Before putting valve into operation, check that :

- the working conditions are compatible with the details given on the identification plate, the instruction notice and the manufacturer's detail,
- the valve works effectively when tried (carry out a few opening and closing operations of the closing system),
- the valve is free-pollution inside.

On a new installation or after maintenance, the circuit must be rinsed with the valve completely open in order to remove solid matter which may damage the internal parts of the valve.

Commissioning :

The installation should be put under pressure progressively to avoid damage which might occur to internal components.

Make sure that when flow stops the valve maintains pressure well and that there is no water-hammer which might damage the valve or installation.

If there is water-hammer, an anti-water hammer system must be added to the installation.

During a prolonged stoppage, a change in the state of the fluid may result in damage when the installation is brought back into service (solidification...).

Establish an adequate procedure program for cleaning the system.

Maintenance

• Removing :

1. Unscrew the 4 plugs (N° 5) and remove the 4 seals (N° 4).
Tip over the body (N° 1) if necessary
2. Remove the upper stem (N° 3)
3. Use this to remove the lower stem (N° 3)

WARNING: Keep the springs (N° 8 and 8*) in compression during this operation.

Remove the 2 plates (N° 9) and the bearings (N° 6 and 6*)

• Reassembly :

Before reassembling the valve, check the condition of the seal. If necessary, clean and grease it by using appropriate grease.

1. Put in place 2 seals (N° 5) on the same side of the body (N° 1)
 2. Thread 2 plugs (N° 5) on the same side with a stop on the body (N° 1)
 3. Place the 2 wings flat (N° 9) on the body (N° 1)
 4. Engage the lower stem (N° 3) by sliding it into the body (N° 1), while positioning in the following order :
 - The first bearing (N° 6)
 - The first ear of the plate (N° 9)
 - The second bearing (N° 6)
 - The first ear of the second plate (N° 9)
 - The spring (N° 7)
 - The bearing (N° 6*)
 - The spring (N° 8*)
 - The second ear of the plate (N° 9)
 - The third bearing (N° 6)
 - The second ear of second plate (N° 9)
 - The fourth bearing (N° 6)
 5. Push the stem against the seal (N° 4) by using the second stem to complete the operation
 6. Put in place the upper stem (N° 3)
 7. Place the 2 last seals (N° 4)
 8. Screwed the 2 last plugs (N° 5)
 9. Tighten then at Nm torques
- Once the reassembly completed, test the device to verify its tightness.

Type 815

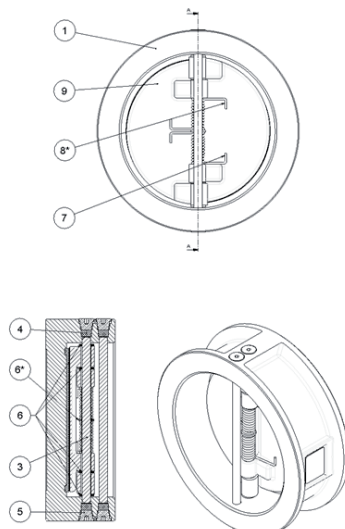

Operation

Direction for use :

- Solid line: Valve completely open
- Dotted line: opening stage of valve

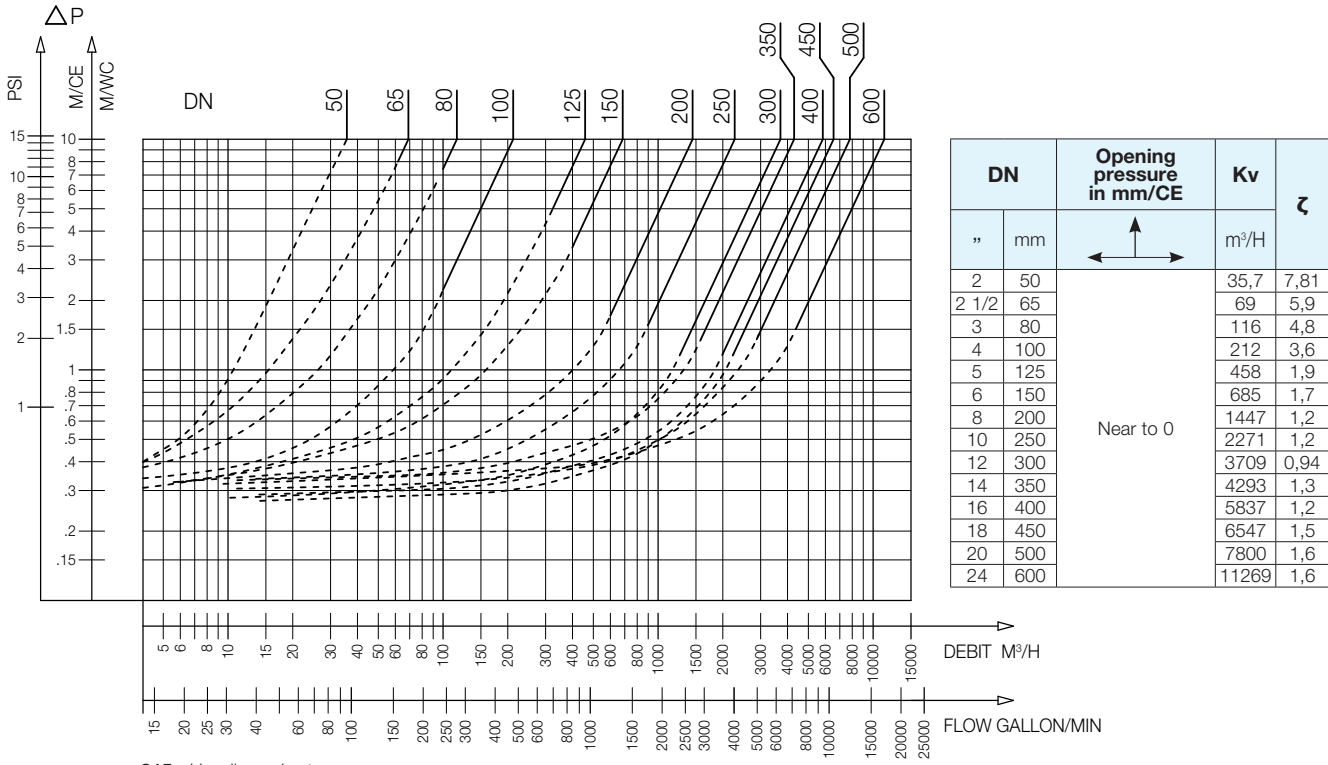

815 - Headloss chart

Sizing

	A	B	C	D
”	mm	mm	mm	mm
2	50	54	60	109
2 1/2	65	54	73	129
3	80	57	89	144
4	100	64	114	170
5	125	70	141	194
6	150	76	168	220
8	200	95	219	286
10	250	108	273	340
12	300	143	324	403
14	350	184	356	460
16	400	191	410	517
18	450	203	457	567
20	500	213	508	627
24	600	222	610	734

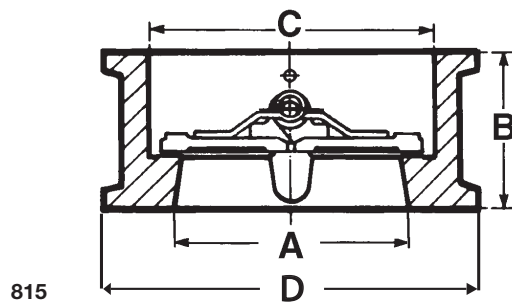

815

The descriptions and photographs contained in this product specification sheet are supplied by way of information only and are not binding.

Socla reserves the right to carry out any technical and design improvements to its products without prior notice. Warranty : All sales and contracts for sale are expressly conditioned on the buyer's assent to Socla terms and conditions found on its website at www.socla.com. Socla hereby objects to any term, different from or additional to Socla terms, contained in any buyer communication in any form, unless agreed to in a writing signed by an officer of Socla.



A WATTS Brand

Socla sas

365 rue du Lieutenant Putier • 71530 Virey-Le-Grand • France

Tel. +33 03 85 97 42 00 • Fax +33 03 85 97 42 42

contact@wattswater.com • www.socla.com

ISO 9001 version 2015 / ISO 18001