

# 10 BIS and 10 BIS RC

Pressure reducing valves

**Desbordes**

**Technical Data Sheet**



## Description

The Desbordes pressure reducing valves 10 BIS and 10 BIS RC bodies are made of bronze. Due to their design, they are not affected by scale or dirt and do not need any maintenance. They can be fitted on compressed air, neutral gases and fuel oil at ambient temperature circuits. For these cases of applications consult us.

- Control and maintain the downstream pressure at an adjustable reduced value, whether there is a flow or not
- Keep an outlet pressure at a constant value, even by variation of the upstream pressure (the downstream pressure cannot vary more than 10% of the variation of the upstream pressure, according to the Standard)
- Guarantee a high flow rate at a constant outlet pressure because of low head loss
- Downstream setting : 1 bar to 6 bar; indicative value according to EN1567
- Downstream setting is possible from 0,5 bar with a compensating spring on RC type (except DN 100)
- Pre-set at 3 bar
- Equipped with 2 pressure gauge connections 1/4" and drain at the bottom of the casing



## 10 BIS and 10 BIS RC

Desbordes pressure reducing valves

DN	PFA in bar	PS in bar				Cat.	Ref.		Weight Kg	
		L1	L2	G1	G2		Water	Other mediums		
1/2	15	25	25	25	x	25	4.3	<b>149B7004</b>	<b>149B7736</b>	1,25
3/4	20	25	25	25	x	25	4.3	<b>149B7005</b>	<b>149B7737</b>	1,75
1	25	25	25	25	x	25	4.3	<b>149B7006</b>	<b>149B7738</b>	2,70
1 1/4	32	25	25	25	x	25	4.3	<b>149B7007</b>	<b>149B7739</b>	4,80
1 1/2	40	25	25	25	x	25	4.3	<b>149B7008</b>	<b>149B7740</b>	6,50
2	50	25	25	25	x	20	4.3	<b>149B7009</b>	<b>149B7741</b>	9,80
2 1/2	65	25	25	25	x	15	4.3	<b>149B7011</b>	<b>149B7743</b>	13,50
3	80	25	25	25	x	12	4.3	<b>149B7012</b>	<b>149B7744</b>	17,90
4	100	25	20	25	x	10	4.3	<b>149B7225</b>	<b>149B7745</b>	33,60

### Type RC

1/2	15	25	25	25	x	25	4.3	<b>149B7020</b>	(consult us)	1,25
3/4	20	25	25	25	x	25	4.3	<b>149B7021</b>	(consult us)	1,75
1	25	25	25	25	x	25	4.3	<b>149B7022</b>	(consult us)	2,70
1 1/4	32	25	25	25	x	25	4.3	<b>149B7023</b>	(consult us)	4,80
1 1/2	40	25	25	25	x	25	4.3	<b>149B7024</b>	(consult us)	6,50
2	50	25	25	25	x	20	4.3	<b>149B7025</b>	(consult us)	9,80
2 1/2	65	25	25	25	x	15	4.3	<b>149B7027</b>	(consult us)	13,50
3	80	25	25	25	x	12	4.3	<b>149B7028</b>	(consult us)	17,90

### Important notice :

L1, L2, G1 and G2 correspond to liquids/gas classified into degree of danger according to the Pressure Equipment Directive (PED). The article 4.3 applies to equipments with no CE marking.

Technical features	
Operating temperature	Mini. : -10 °C / Maxi. in permanent service : 80 °C
Permissible operating pressure (PFA) in water	See table above
Maximum permissible pressure (PS) other mediums	See table above
Connection	Female/female, BSP thread
Gauge connection	1/4"
Mediums	Membrane EPDM : water Other medium : consult us

**Nomenclature and materials**

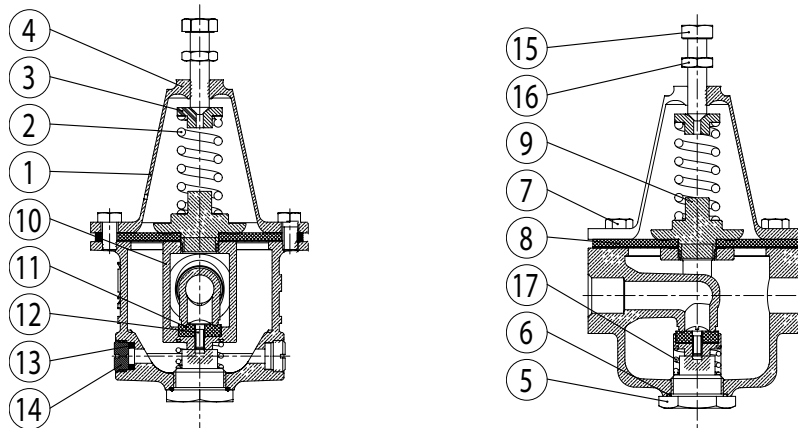

N°	Designation	Materials	EURO	ANSI
1	Body	Bronze	EN1982 CuSn5Zn5Pb5-C GS	ASTM B 505
2	Spring	Anticorrosive steel	EN10270-1-SH or VDCrSi EN10270-2	
3	Nut for spring pressing	Brass	EN12164 CuZn39Pb3 R360 mini	ASTM B 124
4	Cap	Barss or Bronze	EN1982 CuZn39Pb1Al-C GM or EN1982 CuSn5Zn5Pb5-C	
5	Plug cover	Brass or Bronze	EN12164 CuZn39Pb3 R360 mini or CuSn5Zn5Pb5-C	
6	O-ring	NBR (Nitrile) or fibre		
7	Screw	Stainless steel	EN10088-3 X5CrNi 18-10	AISI 304
8	Membrane	Water	EPDM	
		Other mediums	FKM	
9	Plate	Brass or Bronze	EN12165 CuZn39Pb2 ou EN1982 CuSn5Zn5Pb5-C	
10	Stirrup	Alu-bronze or DZR brass or Bronze	EN1982 CuAl9-C or EN12165 CuZn36Pb2As H070 or EN1982 CuSn5Zn5Pb5-C	
11	Seal	NBR (Nitrile)		
12	Screw	Stainless steel	EN10088-3 X5CrNi 18-10	AISI 304
13	Seal	NBR (Nitrile)		
14	Pressure gauge plug	DZR brass	EN12165 CuZn36Pb2As-H070	
15	Adjusting screw	Stainless steel	EN10088-3 X5CrNi 18-10	AISI 304
16	Nut	Stainless steel	EN10088-3 X5CrNi 18-10	AISI 304
17*	Compensating spring	Stainless steel	EN10270-3 X10CrNi 18-8	AISI 302

\* For type 10 BIS RC only.  
Nomenclature and list for DN 100 ; consult us.

## Approvals

**ACS** : specific references consult us

**International construction Standards :**

Pressure reducing valves EN 1567  
Thread connection EN ISO 228

## Application

---

The Desbordes 10BIS and 10BIS RC is an ideal pressure reducing valve for industrial buildings and domestic water systems :

- For water distribution, domestic and individual for the protection of the whole sanitary installation (cold and hot water)
- Industrial applications such as : Machines and work stations, laundries, green houses, boiler rooms, compressed air pipeworks, fuel oil. For those applications, consult us.

Factory preset at 3 bar, it protects the whole installation, facilitates the setting of mixing valves, and decreases the hammering and helps to avoid cracks and vibrations in the piping.

Thanks to its weak head losses, it helps to obtain normal flow during simultaneous pumping.

## Installation

---

In domestic water supply the DESBORDES 10BIS and 10BIS RC reducing valves are fitted just after the water meter and thus protect the whole installation. They can be fitted wherever a reducing pressure is needed.

If there is a frost risk, they should be drained.

It can be fitted in any positions (horizontal, upright, upside down, fluid ascending or reversed and inclined...) if you respect the direction of flow as indicated by the arrow engraved on the body.

However if the circuit present a risk of back pressure or hammering we recommend to protect the pressure reducing valve with a check valve directly after its output.

## Fonctionnement

---

### Flow :

During water flow, water pressure exercised on the diaphragm decreases, which allows the spring to relax. The piston disc-yoke assembly moves towards the bottom to allow the water to pass.

### Flow stoppage :

When water flow stops, the downstream pressure pushes on the diaphragm again, the spring goes back to its initial position, which leads to the valve closing, stopping water from flowing freely.

## Setting

---

The adjustment must be done without flow ie no downstream outflow. The 10 and 10 RC pressure reducing valve is factory pre-set at 3 bar.

They remain adjustable within a 1 bar to 6 bar range.

RC type (compensating spring) allow an upstream setting from 0.5 bar (except DN 100).

To increase the pressure, tighten the adjusting screw (clockwise as you look at the screw from above). To reduce the pressure, undo the adjusting screw (anticlockwise as you look at the screw from above), slightly open a tap for a moment, close again, then tighten the screw again until you obtain a desired pressure.

Water hammers can damage the reducing valve. When commissioning, open slowly and gradually the valve at the upstream side. A booster unit with a sudden start close to the pressure reducer requires the safety of an absorption tank. Just like by any intervention on the pipework, the circuits must be rinsed beforehand.

Max. upstream pressure : 25 bar.

## Maintenance

Due to the special design, the Desbordes 10BIS and 10BIS RC pressure reducing valve is not affected by scale or dirt and does not need any maintenance if is fitted by a professional.

Diaphragm, spring, seat, valve are largely dimensioned to allow precise and constant adjustment allowing a high flow.

## Operation

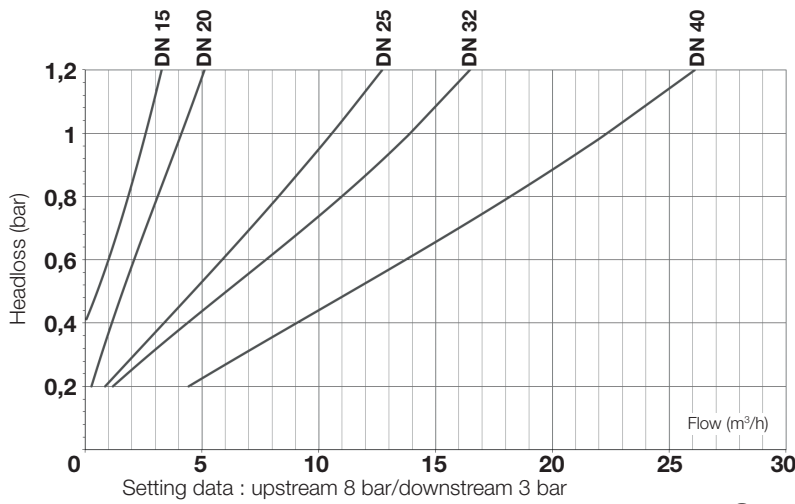

DN (mm)	Q1 (m³/h) v=1m/s	Q2 (m³/h) v=2m/s	Kv
15	0,65	1,3	2,6
20	1,1	2,25	4
25	1,8	3,5	10,5
32	2,9	5,8	14
40	4,5	9	22,5
50	7	14	31
65	12	24	42,5
80	18	36	46
100	28,5	56,5	67,5

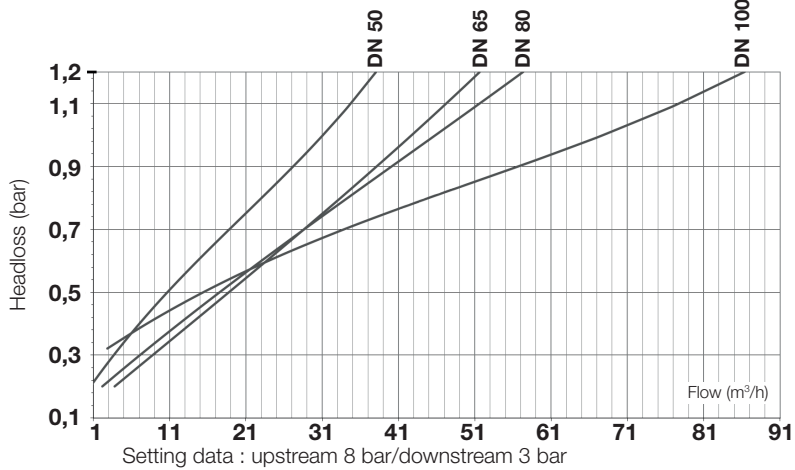

Kv : Flow in m<sup>3</sup>/h when the output pressure becomes 1 bar lower than its zero flow setting

10 BIS and 10 BIS RC - Headloss chart

## Cavitation

Checking if the differential of pressure, between the upstream and the desired downstream pressure, is not too large, is necessary to avoid cavitation risk.

By putting into the graph hereafter, the upstream value and the desired downstream pressure, 2 results are possible :

- Zone A : The point is in the no-cavitation zone, normal duty.
- Zone B : The point is in the cavitation zone : continuous operation in this zone can cause rapid damage of the internal parts. If the pressure reducing valve is to operate in this zone, contact us.

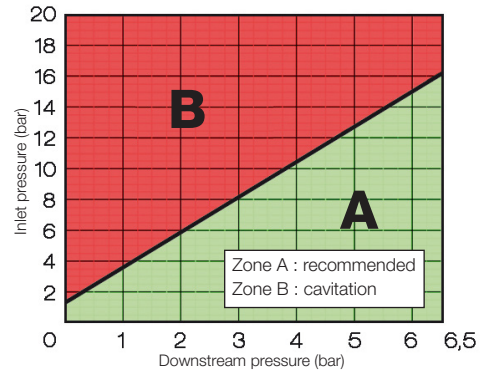

## Sizing

DN	D		A	B	C	G
	"	mm				
10	3/8	12/17	48	120	92	92
15	1/2	15/21	48	120	92	92
20	3/4	20/27	55	130	108	108
25	1	26/34	60	160	123	123
32	1 1/4	33/42	77	180	155	155
40	1 1/2	40/49	84	205	172	172
50	2	50/60	105	235	198	198
65	2 1/2	66/76	118	270	215	215
80	3	80/90	143	300	234	234
100	4	102/114	120	350	250	260

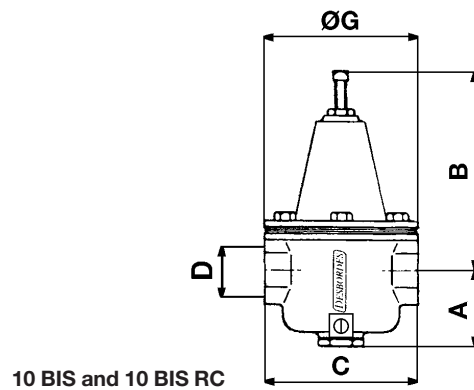

10 BIS and 10 BIS RC

The descriptions and photographs contained in this product specification sheet are supplied by way of information only and are not binding.

Socla reserves the right to carry out any technical and design improvements to its products without prior notice. Warranty : All sales and contracts for sale are expressly conditioned on the buyer's assent to Socla terms and conditions found on its website at [www.socla.com](http://www.socla.com). Socla hereby objects to any term, different from or additional to Socla terms, contained in any buyer communication in any form, unless agreed to in a writing signed by an officer of Socla.



A WATTS Brand

Socla sas

365 rue du Lieutenant Putier • 71530 Virey-Le-Grand • France

Tel. +33 03 85 97 42 00 • Fax +33 03 85 97 42 42

contact@wattswater.com • [www.socla.com](http://www.socla.com)

ISO 9001 version 2015 / ISO 18001