

Tilis butterfly valves

DN 50 up to 300 mm

Technical manual



Description

By concentrating the technologies and by integrating technical solutions of the highest levels, Socla fulfils its ambition :

- competitiveness of a standard range,
- reliability,
- comprehensive range thanks to a multiplicity of solutions.

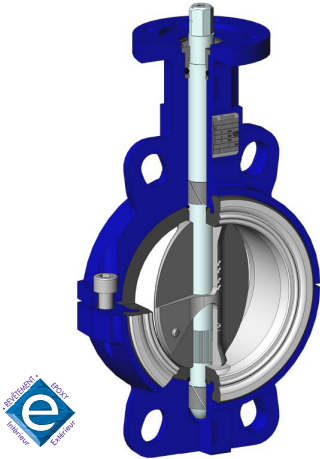

Tilis butterfly valves

DN 50 up to 300 mm

- For processes where hygiene is of the utmost importance, TILIS with PTFE coating (FDA approved), and EPR liner, together with stainless steel 316 disc is highly recommended.
- Vertical and horizontal operating position.
- Two part body for easy dismounting and replacement of the liner.
- Interchangeable disc and liner.
- Body in ductile iron JS1030 and stainless steel
- Body epoxy coated 80µm colour blue RAL

5017 (a lot of other coatings on option, please ask our sales department)

- Wide choice of actuations.

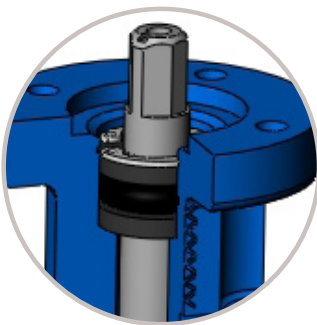

SAFETY

- > Safety anti-ejection circlip keeps shaft in place and allows easy maintenance
- > Safety reinforced by a secondary water tightness.
- > Spline driven one piece shaft connected to floating disc : high reliability of tightness and torque transmission in the long term.

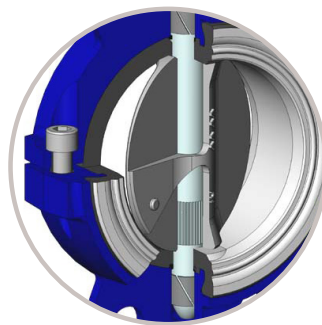

PROTECTION AND RELIABILITY

- > High power transmission with robust grooved connection between the shaft and the disc.
- > Complete protection of the shaft and valve body from fluids.
- > Reliability of movements with self-lubricating bearings.

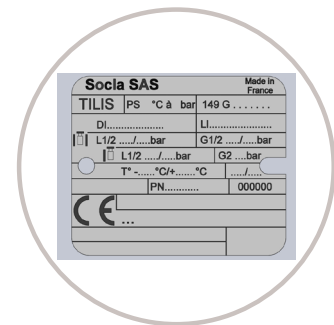

TRACEABILITY

- > Identification and traceability ensured by riveted metal tag : see on page 13.

Spare parts list and materials

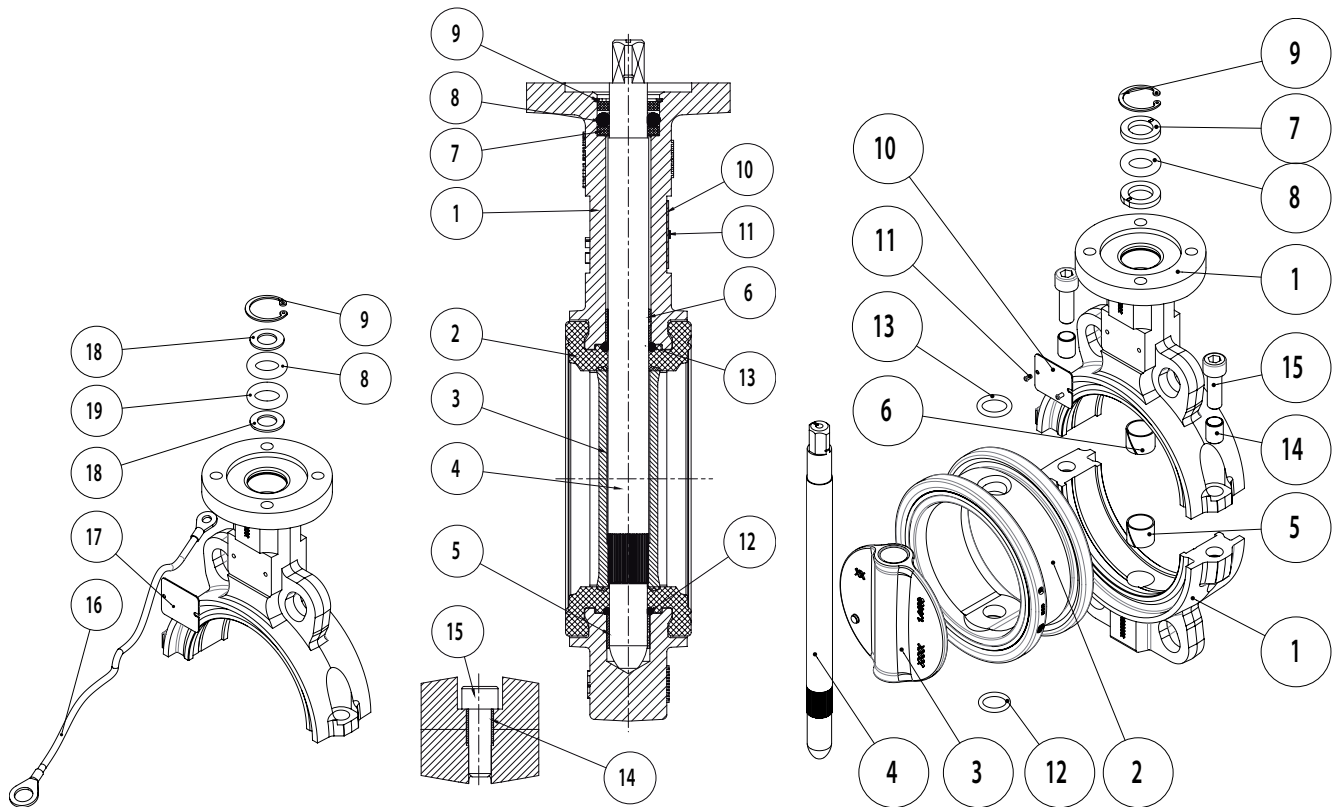

N°	Description	Qty	Materials	EN	ASTM	JIS
1	Body	1	Ductile iron Stainless steel	EN GJS 400-15 (JS 1030) GX5 CrNiMo 19-11-2 (1.4408)	- 316	FCD40 SUS 316
2	Liner	1	EPR / PTFE	-	-	-
3	Disc	1	Stainless steel/ Stainless steel mirror polished	GX5CrNiMo19.11.2 (1.4408)	316	SUS 316
4	Stem	1	Stainless steel	X2 CrNiMo 17-12-2 (1.4404)	316L	SUS 316L
5	Lower anti-friction bearing	1	Zinc coated steel + PTFE	-	-	-
6	Upper anti-friction bearing	1	Zinc coated steel + PTFE	-	-	-
7	Anti-extrusion bush	2	Plastic	Griroy XE883 black 9915 GV4 (DN250 à 300 : IXEF 50V)	-	-
8	O-ring	1	FKM	-	-	-
9	Circlips	1	Stainless steel	X30 Cr13 (1.4028)	420	SUS 420 J2
10	Identification plate	1	Aluminium	EN AW - AL995 (EN AW - 1050A)	-	-
11	Rivet	2	Alu / stainless steel	-	-	-
12	Lower O-ring	1	FKM	-	-	-
13	Upper O-ring	1	FKM	-	-	-
14	Bearing	2	Stainless steel	X5 CrNi18-10 (1.4301)	304	SUS 304
15	Screw	2	Stainless steel	A2-70	304	SUS 304

ATEX special spare parts list

16	Discharge anti-static braid	1	Tinned copper	-	-	-
17	ATEX identification plate	1	Aluminium	EN AW - AL995 (EN AW - 1050A)	-	-
18	Anti-extrusion and sealing	2	Stainless steel	X5 CrNi18-10 (1.4301)	304	SUS 304
19	Braid	1	Tinned copper	-	-	-

DESIGN

According to EN 593 and marking according to EN 19

CONNECTING FLANGES see on page 13

According to EN1092-1 and EN1092-2
ASME/ANSI B16.5
BS10-d and BS10-e
JIS B2238 and JIS B2239

ISO TOP CONNECTION FOR ACTUATIONS

According to EN ISO 5211

FACE TO FACE

According to 558-1 series 20
ISO 5752 series 20
API 609 table 2

TESTS

According to EN12266-1

Resistance and tightness of the body : test P11(1,5 x allowable operating pressure)

Tightness of the seat : test P12 rate A (1,1 x allowable operating pressure)

According to EN12266-2

Anti-static design : test F21

EUROPEAN DIRECTIVES

Our butterfly valves are in accordance to the safety requirements of the following directives. :

• Directive 2014/68/UE : Equipments under pressure PED (Pressure Equipment Directive)

Applies to the design, manufacturing and the assessment of the conformity of pressure equipment, the maximum allowable pressure of which is 0.5 bar.

Pressure equipment for water supply, distribution, and disposal of water is excluded. Depending on the type of pressure equipment, maximum allowable temperature (PS), DN, physical nature of the fluid (liquid, gas or vapour) and the degree of danger of the fluid (group1/2)*, the directive classifies this same equipment into different categories (article 3.3, I, II, III, IV), required for the assessment of conformity with CE marking. The equipment defined in article 3.3 of the directive must not bear the CE marking.

(*) Group 1 : according to rule CE 1272/2008.

Group 2 : all other fluids.

Important notice : the indicated pressure for the different categories of fluids (L1/L2/G1/G2) is under no condition a guarantee of use. Therefore, it is essential to validate the use of products under given operating conditions. Socla is not responsible for alteration of the products to working conditions not previously specified by the customer.

Directive 2014/34/UE : ATEX (EXplosive ATmospheres)

This directive is only applicable for the following atmospheric conditions : $-20^{\circ}\text{C} < T < +60^{\circ}\text{C}$; $0,8 \text{ bar} \leq P \leq 1,2 \text{ bar}$.

In this risk analysis, the fluid which passes through the valve is not taken into account. It is under the responsibility of the user to take into consideration the risks generated by the fluid like : heating of the surface of the valve, internal chocks generated by granulates, wave of chocks due to the installation (water hammering), or the risks due to foreign bodies which are inside the installation.

Classification of the bare shaft valve : The marking of the bare shaft valve is : Ex II 2 DG.

Classification of the set valve + actuation :

- Valve with a hand lever : The use of hand levers produced by Socla within a ATEX area do not represent additional risks. The valve with a hand lever is in conformity to the marking : Ex II 2 DG.
- Valve with other actuations : The classification of the valve + actuation supplied by Socla is similar to the lowest classification of the components which composed the assembly.

No additional marking will be used to indicate the classification of the assembly.

If a single element of the combination does not carry the ATEX mark, then the entire valve/control combination does not conform to the ATEX directive. The classification of the equipment allows its use in a determinate area; an use in another area is under the responsibility of the user.

Directive 2006/42/CE : Machinery Directive

In its Appendix I it sets a certain number of Essential Health and Safety Requirements which must be met. It applies to motorised butterfly valves, (with electric, pneumatic or hydraulic actuators). According to this Directive, these sets are "Partly Completed Machineries" designed for being integrated into a machine.

"Partly Completed Machinery" means an assembly which is almost machinery but which cannot in itself perform a specific application. A drive system is partly completed machinery. Partly completed machinery is only intended to be incorporated into or assembled with other machinery or other partly completed machinery or equipment, thereby forming machinery to which this Directive applies.

An instruction notice specifying the installation characteristics and the commission of the Tilis is added to every product; It is available on our web site www.socla.com or on request by our sales department.

Pressure

DIRECTIVE 2014/68/UE EQUIPMENTS UNDER PRESSURE

Products manufactured in conformity with the requirements of the directive, according to pressure, DN and fluid (see on the precedent page).

LINERS	DN mm	Cat.	MOUNTING	PFA	PS			
					L1	L2	G1	G2
EPR/PTFE	50 to 100	I	Flanges	10	10	10	10	10
			End of line	6	6	6	6	
	125 & 150	II	Flanges	10	10	10	10	
			End of line	6	6	6	6	
	200 to 300	II	Flanges	6	6	6	6	
			End of line	4	4	4	4	

For Class II valves, the minimum body temperature is:
- 10 for ductile iron 5.3106 EN-GJS-400-15)

NOTE : Butterfly valves of category II used as «end of line», please consult us.

PS : Maximum allowable pressure (in bar) according to Directive 2014/68/UE

PFA : Allowable operating pressure (in bar) for supply, distribution and disposal of water.

Applications

- Industrial applications such as : Food fluids, mineral water, cosmetic process, detergents, fertilisers and weed-killers.
- On request, we can supply butterfly valves type TILIS conformed to the directive 2014/34/UE (products or systems used in a explosive atmosphere).

Installation

General remarks :

For safety reasons, the installation must take place under the supervision of authorised people taking account of local safety instructions and advice.

The handling of butterfly valves and their controls must be done by staff trained in all technical aspects of their operation.

Before installation the pipes must be depressurised and purged (empty of its fluid) in order to avoid any danger to the operator.

The pipe work must be correctly aligned so that no extra stress is exerted on the valve casing.

In ATEX zone, check that the pipes are connected to the earth. Do not use insulating pipes (PVC...)

Check the compatibility of the connection flanges against the operating pressure : the PN number of the flanges must be greater or equal to the operating pressure.

The valve is a machined piece of equipment and must not be used to prise apart the flanges.

An instruction notice specifying the installation characteristics and the commission of the Tilis is added to every product when the ATEX version is specified;. It is available on our web site www.socla.com or on request by our sales department.

Installation conditions :

It is recommended that the distances mentioned below be respected in order to prolong the life time of the valve.

Mounting the valve close to pipe work junctions places it in turbulent zones which increase its wear.

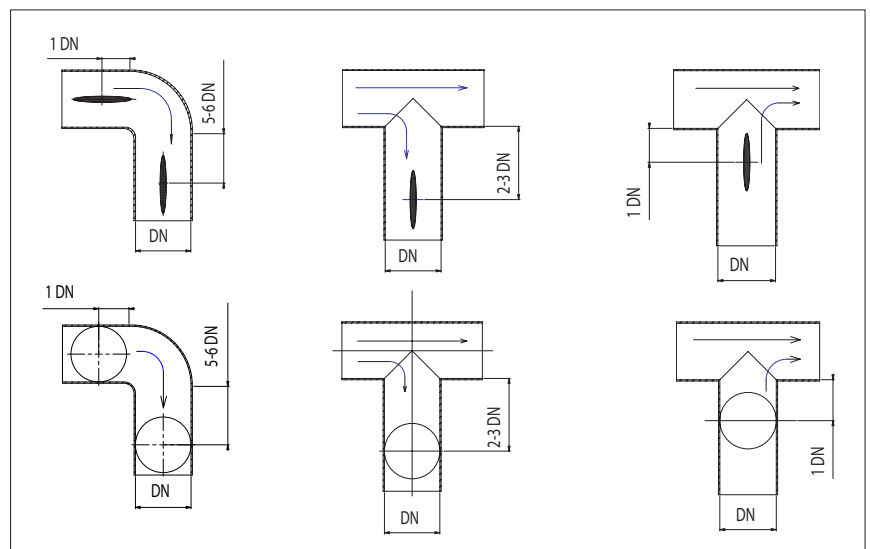

Functioning characteristics

Torque values

DN	50	65	80	100	125	150	200	250	300
Torques for water - Nm	50	61	70	120	130	165	350	410	650

NOTE : Applications: liquids, one actuation per month, torque value after 10 actuations, PS 10 up to DN150, PS 6 for DN200 to 300.

Pressure/temperature diagram

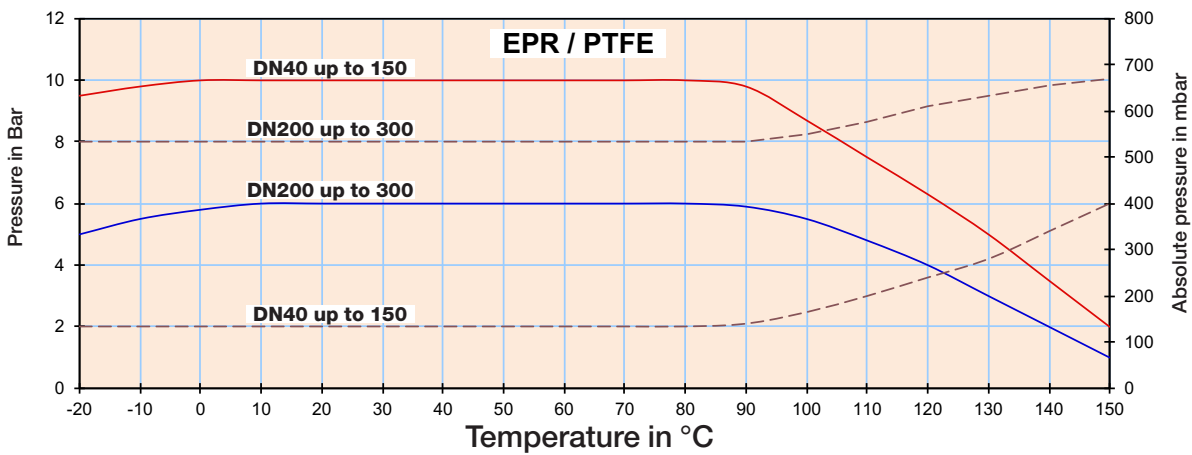

Flow rate (Kv)

OPENING STAGE - Stainless steel disc									
DN	10°	20°	30°	40°	50°	60°	70°	80°	90°
50	-	-	1	8	18	33	54	71	79
65	-	-	6	19	41	76	118	158	174
80	-	3	18	43	79	138	211	252	275
100	-	15	38	83	154	253	368	458	496
125	-	20	61	134	249	399	599	792	883
150	5	37	100	200	374	600	863	1109	1212
200	15	76	200	399	680	1099	1666	2196	2500
250	40	150	333	621	1084	1765	2652	3517	3948
300	60	219	500	989	1736	2770	4097	5118	5635

The butterfly valve is not the best product for regulating. Nevertheless, the Tilis butterfly valve can be used to regulate by an opening stage between 30° and 90°.

A regulation in the opening stage lower than 30° is not advisable because of over speed, cavitation effect, which could damage prematurely the valve.

The maximum flow velocity of the fluid through the valve must not exceed :

- **3 m/s for liquid fluids.** Between 3 and 5m/s, the use of the Tilis butterfly valve is possible, but the phenomena of cavitation, noise, vibration and water hammering increase.
- **20m/s for gas.** Between 20 and 25m/s, the use of the Tilis butterfly valve is possible, but the phenomena of cavitation, noise, vibration and water hammering increase.
- for gas and and pulverulent or paste fluids : please consult us.

Kv = volume of water in m3/h through a valve at a preset opening stage and under a head loss of 1 bar.

Flow rate (Kv)

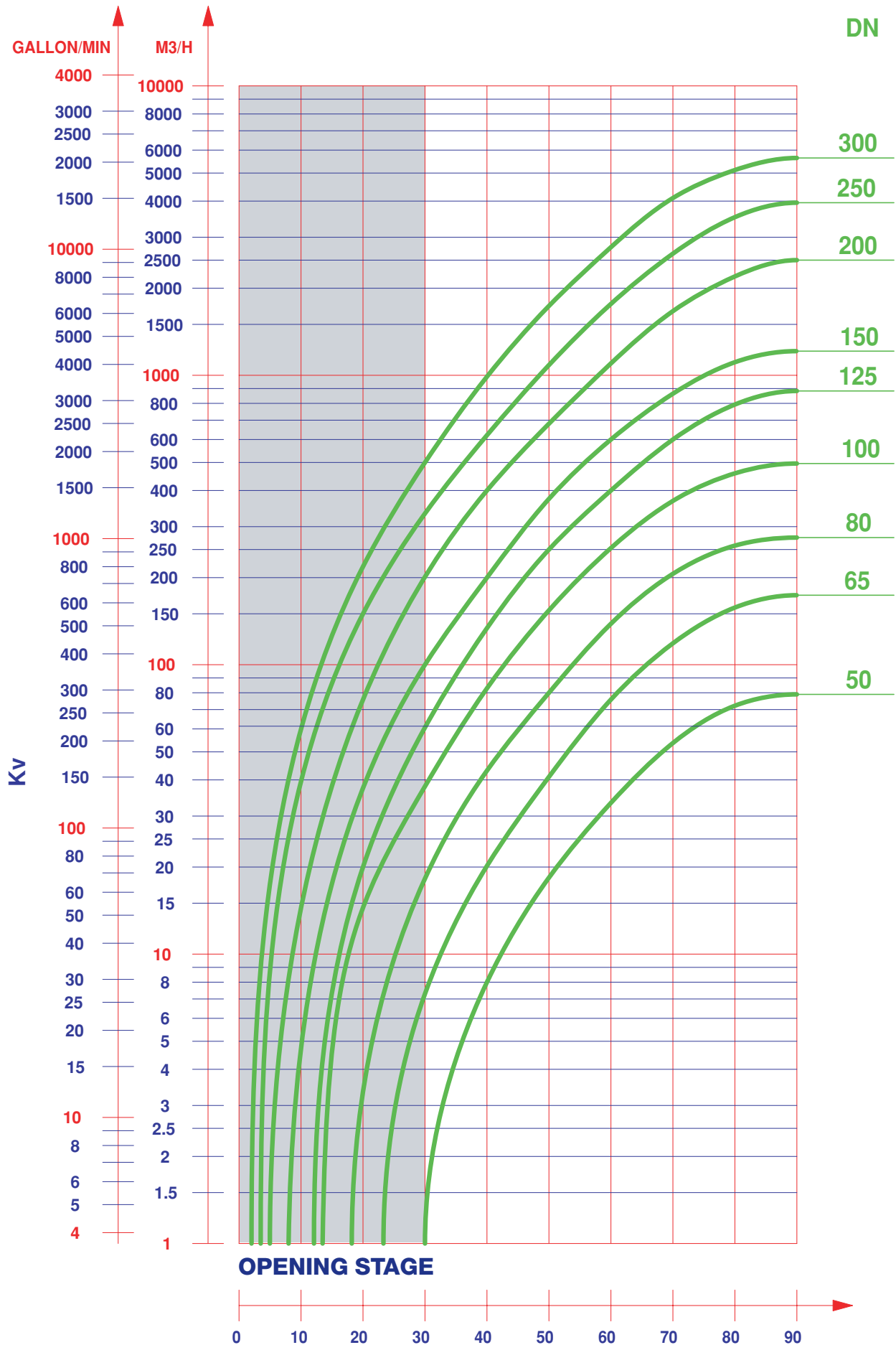

Head loss diagram (Δp)

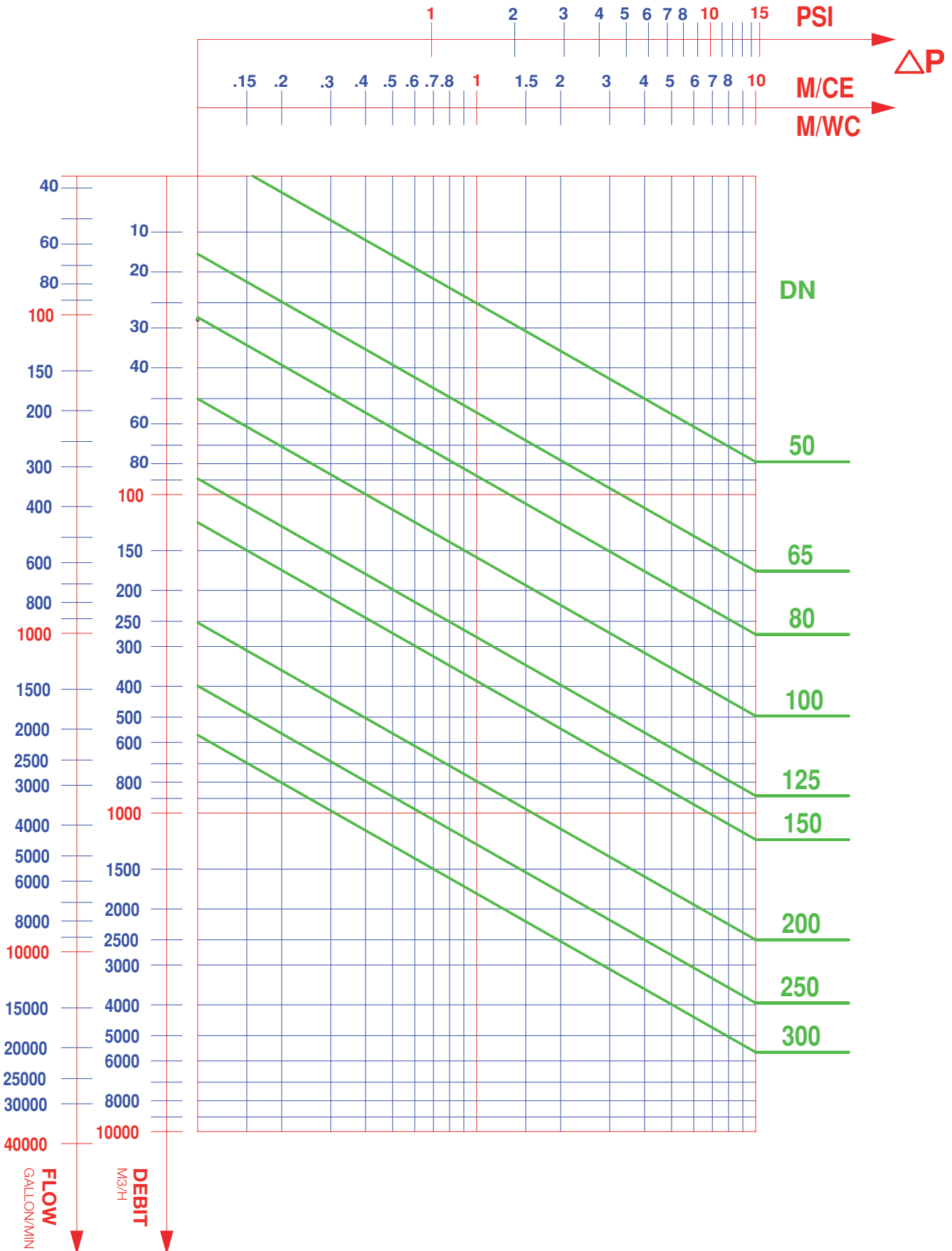

Overall dimensions

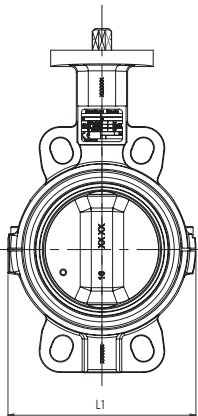
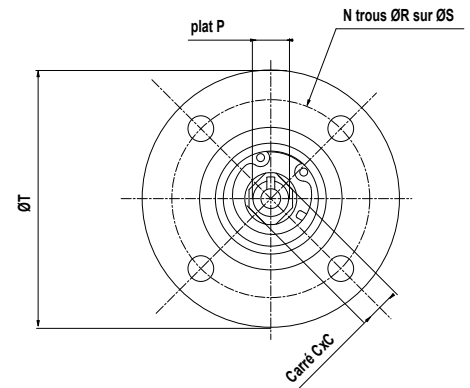
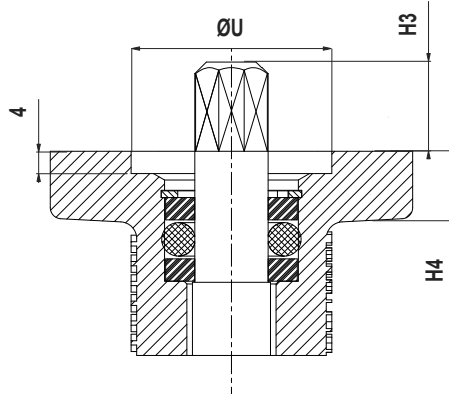
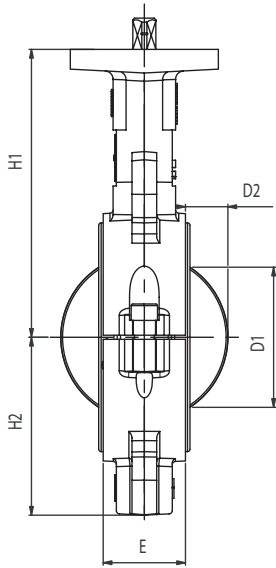

4 Centering lugs

Diameter	Face to face	Overall dimensions						ISO top according to ISO 5211						Square drive outlet			Travel of the disc		Weight
		DN	NPS	E	L1	H1	H2	H4	N	Ø R	Ø S	Ø T	Ø U	N°	□C	H3	plat P	D1	
50	2	43	158	136	63	12	4	6,5	50	65	36	F05	11	16	11	29,5	4,5	3,6	
65	2 1/2	46	174	145	71	12	4	6,5	50	65	36	F05	11	16	11	48	10,5	3,8	
80	3	46	136	151	90	12	4	6,5	50	65	36	F05	11	16	11	67,5	18	3,4	
100	4	52	165	175	107	12	4	8,5	70	90	56	F07	14	19	14	87,5	25	5,2	
125	5	56	193	190	120	12	4	8,5	70	90	56	F07	14	19	14	114	35,5	6,8	
150	6	56	224	203	131	12	4	8,5	70	90	56	F07	14	19	14	141	48	7,9	
200	8	60	279	245,5	164,5	16	4	10,5	102	125	71	F10	17	24	20	193	71	13,7	
250	10	68	331	271	200	16	4	10,5	102	125	71	F10	22	24	26	244,5	93	20,5	
300	12	78	381	296	235	16	4	12,5	125	150	87	F12	22	29	26	292,5	112,5	28,2	

2 Centering lugs

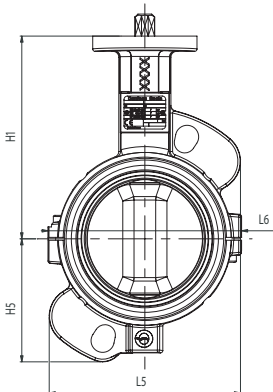

Diameter	Face to face	Overall dimensions						ISO top according to ISO 5211						Square drive outlet			Travel of the disc		Weight
		DN	NPS	E	L5	L6	H1	H5	H4	N	Ø R	Ø S	Ø T	Ø U	N°	□C	H3	plat P	
50	2	43	121	99	136	72	12	4	6,5	50	65	36	F05	11	16	11	29,5	4,5	2,5
65	2 1/2	46	136	117	145	81	12	4	6,5	50	65	36	F05	11	16	11	48	10,5	3,2
80	3	46	151	136	151	92	12	4	6,5	50	65	36	F05	11	16	11	67,5	18	3,5
100	4	52	166	167	175	106	12	4	8,5	70	90	56	F07	14	19	14	87,5	25	5,4
125	5	56	132	194	190	126	12	4	8,5	70	90	56	F07	14	19	14	114	35,5	7
150	6	56	139	225	203	146	12	4	8,5	70	90	56	F07	14	19	14	141	48	8
200	8	60	164	279	245,5	174	16	4	10,5	102	125	71	F10	17	24	20	193	71	14
250	10	68	188	332	271	209	16	4	10,5	102	125	71	F10	22	24	26	244,5	93	20,7
300	12	78	166	382	296	237	16	4	12,5	125	150	87	F12	22	29	26	292,5	112,5	27,9

Tapped lugs

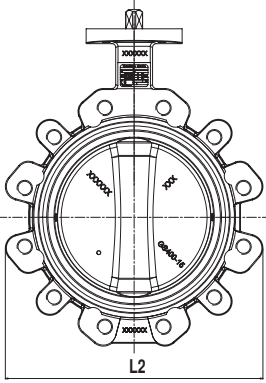

Diameter		Face to face	Overall dimensions				ISO top according ISO 5211						Square drive outlet			Travel of the disc		Weight
DN	NPS	E	L2	H1	H2	H4	N	Ø R	Ø S	Ø T	Ø U	N°	□ C	H3	plat P	D1	D2	kg
50	2	43	161	136	69	12	4	6,5	50	65	36	F05	11	16	11	29,5	4,5	3,8
65	2 1/2	46	175	145	73	12	4	6,5	50	65	36	F05	11	16	11	48	10,5	4,3
80	3	46	179	151	89	12	4	6,5	50	65	36	F05	11	16	11	67,5	18	4,5
100	4	52	206	175	103	12	4	8,5	70	90	56	F07	14	19	14	87,5	25	6,6
125	5	56	238	190	118	12	4	8,5	70	90	56	F07	14	19	14	114	35,5	9
150	6	56	265	203	132	12	4	8,5	70	90	56	F07	14	19	14	141	48	10,1
200	8	60	336	245,5	167	16	4	10,5	102	125	71	F10	17	24	20	193	71	19,6
250	10	68	397	271	198	16	4	10,5	102	125	71	F10	22	24	26	244,5	93	26
300	12	78	454	296	226	16	4	12,5	125	150	87	F12	22	29	26	292,5	112,5	34

Connecting kit for actuations

We recommend direct mounting of the actuation, otherwise see table below.

DN	NPS	Iso top of the valve	Iso top of the actuation																	
			F03		F04		F05		F07		F10		F12		F14		F16			
			H1	H2	H1	H2	H1	H2	H1	H2	H1	H2	H1	H2	H1	H2	H1	H2		
50	2	F05/□11	195	60	195	60	195	60	195	60	215	80								
65	2 1/2		204		204		204		204		224									
80	3		210		210		210		210		230									
100	4	F07/□14			234	60	234	60	234	60	254	80	254	80	254	80				
125	5		249	249	249		249		269		269		269							
150	6		262	262	262		262		282		282		282							
200	8	F10/□17					324,5	80	324,5	80	324,5	80	324,5	80	334,5	90	334,5	90		
250	10	F10/□22			350	350	350		350		350		350		350		350		360	360
300	12	F12/□22					375		375		375		375		385		385		385	385

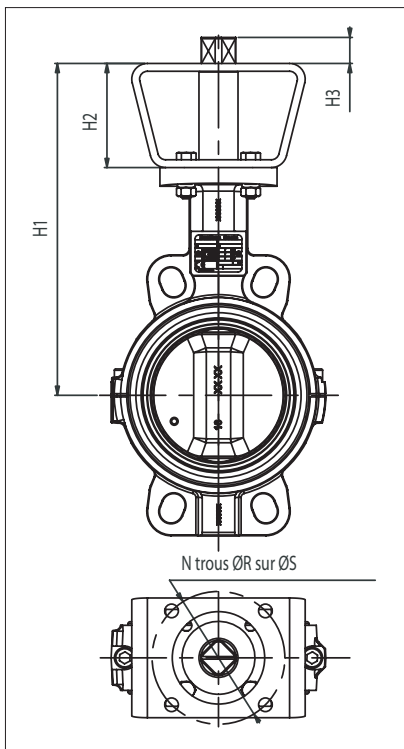

N°	N	ØR	ØS
F03	4	5,5	36
F04	4	5,5	42
F05	4	6,5	50
F07	4	8,5	70
F10	4	10,5	102
F12	4	12,5	125
F14	4	17	140
F16	4	22	165

DN	NPS	Iso top of the valve	Exceeding length of the shaft H3									
			Kit	□9	□11	□14	□17	□22	□27	□36	□46	
50	2	F05/□11	F05									
65	2 1/2		F07	7	9	12	15	20	25			
80	3		F10									
100	4	F07/□14	F04									
125	5		F05									
150	6		F07		9	12	15	20	25	34		
			F10									
			F12									
			F14									
200	8	F10/□17	F05									
			F07									
			F10		9	12	15	20	25	34		
			F12									
			F14									
250	10	F10/□22	F05									
			F07									
			F10			12	15	20	25	34		
			F12									
			F14									
300	12	F12/□22	F07									
			F10									
			F12			12	15	20	25	34	44	
			F14									
			F16									

Reminder of the iso top dimensions EN ISO 5211 (see also the overall dimensions).

Other special executions on request : actuated by par square drive and flat according to EN ISO 5211, subjected to technical feasibility.

Connecting flanges

The Tilis butterfly valve can be mounted with the following connections (other types on request) :

- ✓: possible mounting
- : possible mounting with re-machining
- : impossible mounting

4 Centering lugs, ductile iron EN GJS 400-15 (JS1030)

Diameter		EN 1092-1 & EN 1092-2					ASME/ANSI B16.1 Class 125	ASME/ANSI B16.5 Class 150	ASME/ANSI B16.5 Class 300	BS10		JIS B2238 & JIS B2239		
DN	NPS	PN6	PN10	PN16	PN25	PN40				Table D	Table E	5K	10k	16k
50	2	✓	✓	✓	✓	✓	✓	✓	●	✓	✓	●	✓	●
65	2 1/2	✓	✓	✓	●	●	✓	✓	●	●	●	✓	✓	●
80	3	✓	✓	✓	✓	✓	●	●	●	✓	✓	✓	●	●
100	4	✓	✓	✓	●	●	✓	✓	●	✓	●	●	●	●
125	5	✓	✓	✓	●	●	✓	✓	●	✓	✓	✓	✓	●
150	6	✓	✓	✓	●	●	✓	✓	●	✓	✓	✓	✓	■
200	8	✓	✓	✓	●	●	✓	✓	■	✓	✓	●	●	●
250	10	✓	✓	✓	●	●	✓	✓	■	●	✓	✓	✓	●
300	12	✓	✓	✓	●	●	✓	✓	■	✓	✓	✓	■	■

2 Centering lugs, stainless steel GX5 CrNi 19-11-2 (1.4408)

Diameter		EN 1092-1 & EN 1092-2					ASME/ANSI B16.1 Class 125	ASME/ANSI B16.5 Class 150	ASME/ANSI B16.5 Class 300	BS10		JIS B2238 & JIS B2239		
DN	NPS	PN6	PN10	PN16	PN25	PN40				Table D	Table E	5K	10k	16k
50	2	✓	✓	✓	✓	✓	✓	✓	●	✓	✓	✓	✓	
65	2 1/2	✓	✓	✓	●	●	✓	✓	●	✓	✓	✓	✓	●
80	3	✓	✓	✓	✓	✓	✓	✓	✓	✓	✓	✓	●	✓
100	4	✓	✓	✓	✓	✓	✓	✓	✓	✓	✓	●	✓	✓
125	5	✓	✓	✓	✓	✓	✓	✓	✓	✓	✓	✓	✓	✓
150	6	✓	✓	✓	✓	✓	✓	✓	✓	✓	✓	✓	✓	●
200	8	✓	✓	✓	✓	✓	✓	✓		✓	✓	✓	✓	✓
250	10	✓	✓	✓	✓	✓	✓	✓		✓	✓	✓	✓	✓
300	12	✓	✓	✓	✓	✓	✓	✓		✓	✓	✓		

Tapped lugs, ductile iron EN GJS 400-15 (JS1030) and stainless steel GX5 CrNi 19-11-2 (1.4408)

Diameter		EN 1092-1 & EN 1092-2					ASME/ANSI B16.1 Class 125	ASME/ANSI B16.5 Class 150	ASME/ANSI B16.5 Class 300	BS10		JIS B2238 & JIS B2239		
DN	NPS	PN6	PN10	PN16	PN25	PN40				Table D	Table E	5K	10k	16k
50	2	✓	✓	✓	✓	✓	✓	✓		✓	✓	✓	✓	
65	2 1/2	✓	✓	✓			✓	✓		✓	✓	✓	✓	
80	3	✓	✓	✓	✓	✓	✓	✓		✓	✓	✓	✓	
100	4	(1)	✓	✓	✓	✓	✓	✓			✓		✓	✓
125	5	✓	✓	✓			✓	✓		✓	✓	✓	✓	
150	6	✓	✓	✓			✓	✓		✓	✓	✓	✓	
200	8	✓	✓	✓	✓		✓	✓		✓	✓	✓	✓	✓
250	10	✓	✓	✓	✓		✓	✓			✓	✓	✓	
300	12	✓	✓	✓			✓	✓		✓	✓	✓		

(1) Possible mounting if the butterfly valve is inclined at 22,5°

Attention : the body of the Tilis butterfly valve is not a multi-connection body (connection to many flanges of different sizes). Generally, every connection relates to a different reference of finished products.

End of line mounting and downstream removing

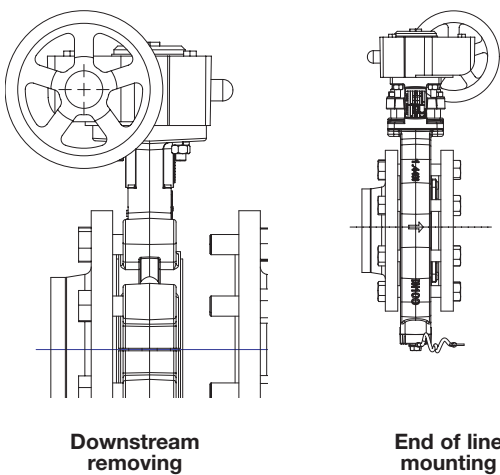

The end of line mounting and the downstream removing, at ambient temperature, of the Tilis butterfly valve is limited to the pressure mentioned on page 5 according to the PED directive 2014/68/UE .

These mountings are only possible on bodies with tapped lugs.

Type of flange

The Tilis butterfly valve has been designed to be mounted on normal standard flanges. Only standard flanges type 11, 21 and 34 according to EN 1092 are quite compatible.

For other types of flanges, refer to the table below. Non appropriate connections will cancel our guarantee.

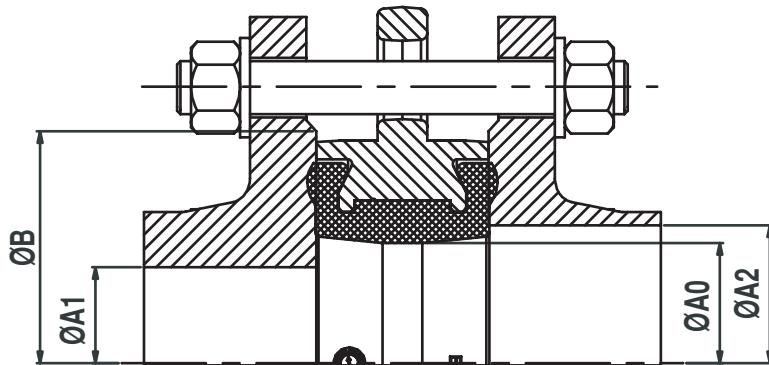

DN		Ø A0	Ø A1 mini	Ø A2 maxi	Ø B mini
mm	"	mm	mm	mm	mm
50	2	50	36	59	90
65	2 1/2	65	54	74	110
80	3	80	73	88	128
100	4	100	93	116	148
125	5	125	119	143	178
150	6	150	146	166	202
200	8	200	196	224	258
250	10	250	246	280	312
300	12	300	296	329	365

NOTE : The use of expansion seals, as well as the use of elastomer coated flanges, between the flange and the valve are strictly forbidden.

Tag and traceability

N°	Description
1	Name of the valve
2	Reference
3	Material of the disc
4	Material of the liner
5	Pressure PS between flanges L1/L2 (liquid)
6	Pressure PS between flanges G1/G2 (gas)
7	Pressure PS end flange L1/L2 (liquid)
8	Pressure PFA water 20°C
9	Pressure PS end flange G2 (gas)
10	Number of manufacturing order
11	Notified Body Number for the Directive PED 2014/68/UE
12	Manufacturing date
13	Connecting flanges
14	Limit of use
15	Approval information zone
16	Marking relating to the Directive ATEX 2014/34/UE

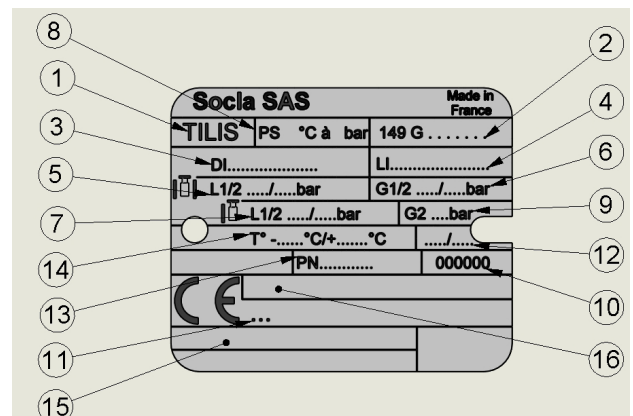

Bolts and nuts

Note : We do not supply bolts and nuts.

DN	NPS	a	e	EN 1092 PN6			EN 1092 PN10			EN 1092 PN16			EN 1092 PN25			ASME / ANSI B16.5 Class 150		
				* Nb rods or Nb screw	ØV	c	* Nb rods or Nb screw	ØV	c	* Nb rods or Nb screw	ØV	c	* Nb rods or Nb screw	ØV	c	* Nb rods or Nb screw	ØV UNC**	c
50	2	41	18	4	M12	18	4	M16	24	4	M16	24	4	M16	24	4	5/8"	24
65	2 1/2	44	20	4	M12	18	4	M16	24	4	M16	24	8	M16	24	4	5/8"	24
80	3	44	20	4	M16	24	8	M16	24	8	M16	24	8	M16	24	4	5/8"	24
100	4	50	24	4	M16	24	8	M16	24	8	M16	24	8	M20	26	8	5/8"	24
125	5	54	26	8	M16	24	8	M16	24	8	M16	24	8	M24	32	8	3/4"	26
150	6	54	26	8	M16	24	8	M20	26	8	M20	26	8	M24	32	8	3/4"	26
200	8	58	28	8	M16	24	8	M20	26	12	M20	26	12	M24	32	8	3/4"	26
250	10	66	32	12	M16	24	12	M20	26	12	M24	32	12	M27	32	12	7/8"	26
300	12	76	36	12	M20	26	12	M20	26	12	M24	32	16	M27	32	12	7/8"	26

DN	NPS	a	e	BS10-d			BS10-e			JIS2238 & JIS2239 5K			JIS2238 & JIS2239 10K			JIS2238 & JIS2239 16K		
				* Nb rods or Nb screw	ØV UNC	c	* Nb rods or Nb screw	ØV UNC	c	* Nb rods or Nb screw	ØV	c	* Nb rods or Nb screw	ØV	c	* Nb rods or Nb screw	ØV	c
50	2	41	18	4	5/8"	24	4	5/8"	24	4	M12	18	4	M16	24	8	M16	24
65	2 1/2	44	20	4	5/8"	24	4	5/8"	24	4	M12	18	4	M16	24	8	M16	24
80	3	44	20	4	5/8"	24	4	5/8"	24	4	M16	24	8	M16	24	8	M20	26
100	4	50	24	4	5/8"	24	8	5/8"	24	8	M16	24	8	M16	24	8	M20	26
125	5	54	26	8	5/8"	24	8	5/8"	24	8	M16	24	8	M20	26	8	M22	26
150	6	54	26	8	5/8"	24	8	3/4"	26	8	M16	24	8	M20	26	12	M22	26
200	8	58	28	8	5/8"	24	8	3/4"	26	8	M20	26	12	M20	26	12	M22	26
250	10	66	32	8	3/4"	26	12	3/4"	26	12	M20	26	12	M22	26	12	M24	32
300	12	76	36	12	3/4"	26	12	7/8"	26	12	M20	26	16	M22	26	16	M24	32

*** WAFER TYPE BODY:**

Assembly by rods : number of nuts and washer = 2 x Number of rods (above)

Assembly by bolts : Number of nuts = Number of screws (above) and number of washer = 2 x Number of nuts

*** LUG TYPE BODY :**

Assembly by screws : Number of screw per face (above) and number of washer is the same

**** ASME / ANSI B16.5 CLASS 150 : ØV UNC THREADING IN INCH ; FOR METRIC THREADING, PLEASE CONSULT US.**

Bolts and nuts

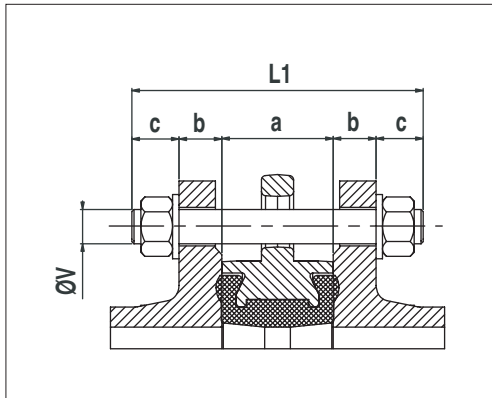

For wafer type body ; assembly by rods :

$$L1 = a + 2(b+c)$$

L1 = l minimum length of rods

a = width of the butterfly valve

b = thickness of the flange (customer)

c = thickness of washer + thickness of nut + exceeding length of the rod.

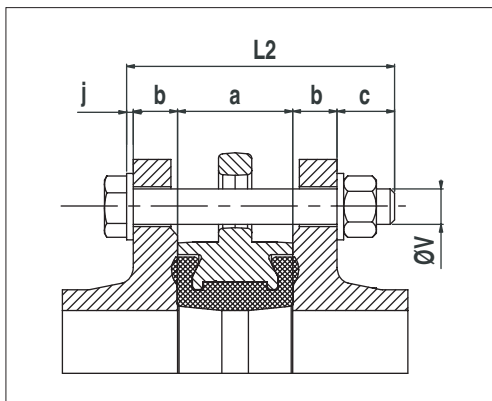

For wafer type body ; assembly by bolts :

$$L2 = a + 2b + c + j$$

L2 = minimum length of rods

a = width of the butterfly valve

b = thickness of the flange (customer)

c = thickness of washer + thickness of nut + exceeding length of the rod

j = thickness of washer

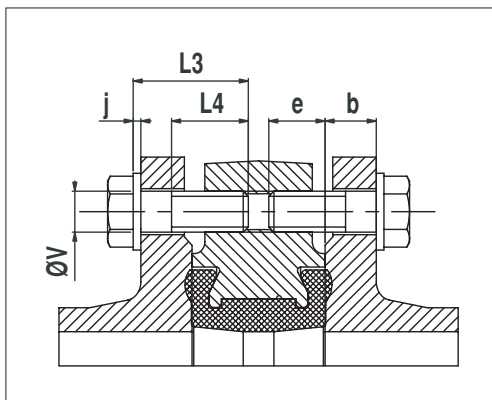

For lug type body ; assembly by screws :

$$L3 \leq b + e + j \text{ with } L4 \geq L3 - (b + j)$$

L3 = maximum length under head of screw

L4 = minimum length of the threading of the screw

a = width of the butterfly valve

b = thickness of the flange (customer)

e = maxi depth of screw

j = thickness of washer

Actuations

Find below the different standard assembly combinations.
For any other information, please ask our technical Department.

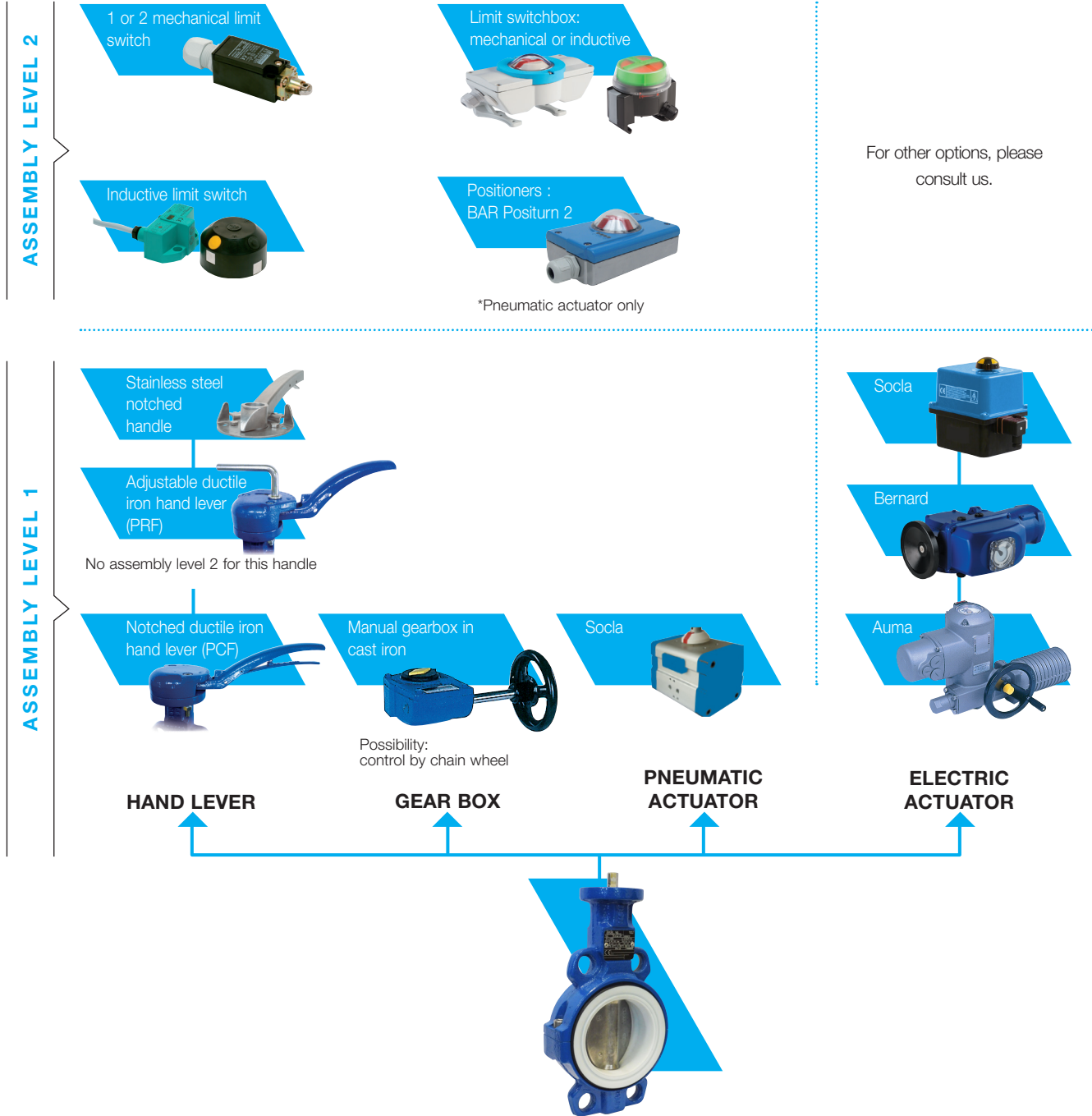

The descriptions and photographs contained in this product specification sheet are supplied by way of information only and are not binding. Socla reserves the right to carry out any technical and design improvements to its products without prior notice. Warranty : All sales and contracts for sale are expressly conditioned on the buyer's assent to Socla terms and conditions found on its website at www.socla.com. Socla hereby objects to any term, different from or additional to Socla terms, contained in any buyer communication in any form, unless agreed to in a writing signed by an officer of Socla.



A WATTS Brand

Socla sas
365 rue du Lieutenant Putier • 71530 Virey-Le-Grand • France
Tél. +33 03 85 97 42 00 • Fax +33 03 85 97 42 42
contact@wattswater.com • www.socla.com
ISO 9001 version 2015 / ISO 18001