

Technical data sheet

Type 5 SP

Water pressure reducing valve Type SECURO

Desbordes®

Applications and special features



- Control and maintain the downstream pressure at an adjustable reduced value, whether there is a flow or not.
- No maintenance required, not affected by scale or dirt.
- Can be installed in any position.
- Can be fitted on an individual device, such as washing machine, water heater...
- Work as pressure reducing valve (standard terminology) as well as "regulator" and as "pressure regulating valve" (when applies for gas).
- Downstream setting : 1bar to 5.5 bar; indicative value according to EN1567.
- Adjustable : supplied pre-set at 3 bar.
- Equipped with 2 plugs 1/4" at the bottom to allow the mounting of a pressure gauge.

Technical description

DN		PFA (bar)	PS (bar)				References	Vvs-nr
"	mm		L1	L2	G2	G2		
3/4	20	16	16	16	16	16	149B7312	

L1, L2, G1 and G2 correspond to liquids/gas classified into degree of danger according to the Pressure Equipment Directive (PED). The article 3.3 applies to equipments with no CE marking.

- **Connection** : inlet male, outlet union nut, BSP thread.
- **Casing** : chrome plated bronze
- **Permissible operating pressure PFA - water** : See table
- **1/4" pressure gauge connection**
- **Maximum permissible pressure PS - other mediums** : See table
- **θ** : Mini. -10 °C
Maxi. 80 °C
- **Mediums** : water, air and neutral gas
- **Approvals** : ACS
- **International construction Standards**:
Thread connections NF EN ISO 228

Overall dimensions

DN	D		A	B	C	E	Weight
	"	mm	mm	mm	mm	mm	
20	3/4	20/27	29	58	82	50	0,4

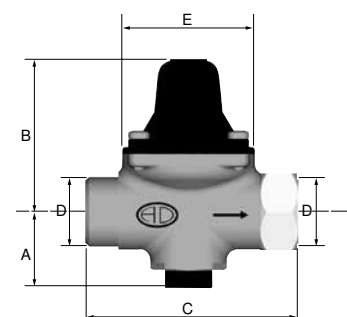

Technical data sheet Type 5 SP- Water pressure reducing valve

Spare parts list and materials

Nb	Description	Material	EURO	ANSI
1	CASING	Chrome plated bronze	CuSn5Zn5Pb5-C	ASTM B 505
2	SEAT	PA (Polyamide)		
3	STEM	Brass	CuZn39Pb3	ASTM B 124
4	NUT	POM (Polyacetal)		
5	CAP	PA (Polyamide)		
6	PLATE WASHER	Stainless steel	X6CrNiTi18-10	AISI 321
7	GUIDE	Brass	CuZn39Pb3	ASTM B 124
8	PLUG	Chrome plated brass	CuZn39Pb3	ASTM B 124
9	GUIDE PLATE	Brass	CuZn39Pb3	ASTM B 124
10	SEAL	EPDM		
11	PLUG	PA (Polyamide)		
12	MEMBRANE	NBR/Polyamide		
13	NUT	Stainless steel	X5CrNiTi18-10	AISI 304
14	SCREW	Stainless steel	X6Cr17	
15	SCREW	Stainless steel	X5CrNiTi18-10	AISI 304
16	SPRING	Anticorrosive steel		
17	O-RING	NBR (Nitrile)	NBR 70 ShA	ASTM B 124
18	O-RING	NBR (Nitrile)	NBR 70 ShA	ASTM B 124
19	O-RING	NBR (Nitrile)	NBR 70 ShA	ASTM B 124
20	O-RING	NBR (Nitrile)	NBR 70 ShA	ASTM B 124
21	CONNECTION	Chrome plated brass		
22	O-RING	NBR (Nitrile)		
23	NUT	Chrome plated brass	CuZn39Pb3	ASTM B 124

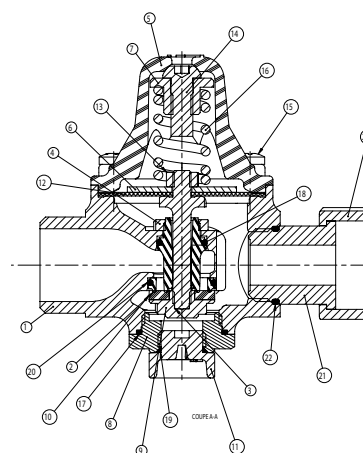

Working principle

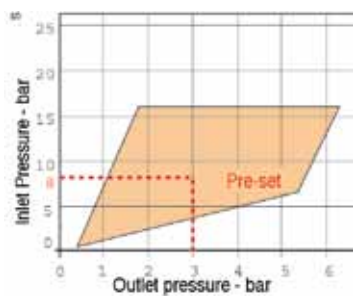

• Pressure setting range

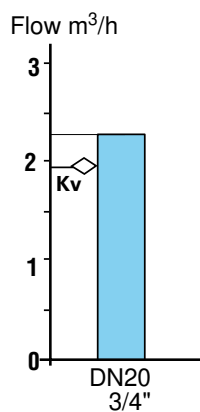

• Flow : maximum flow (0 outlet pressure) under an upstream pressure of 8 bar

Socla can accept no responsibility for possible errors in catalogue, brochures and other printed material. Socla reserve the right to alter its products without notice. This also applies to products already agreed. All trademarks in this material are the property of the respective companies. All right reserved.

Socla SAS

365 rue du lieutenant Putier
 71530 VIREY LE GRAND
 Postal address : BP 10273
 71107 CHALON SUR SAONE Cedex

Tel : 33 3 85 97 42 52
 Fax : 33 3 85 97 97 42
<http://www.socla.com>
 e-mail: commerfr@socla.com